

TECHNICAL INFORMATION | TRACK-MOUNTED IMPACT CRUSHERS

MOBIREX MR 110(i) EVO2

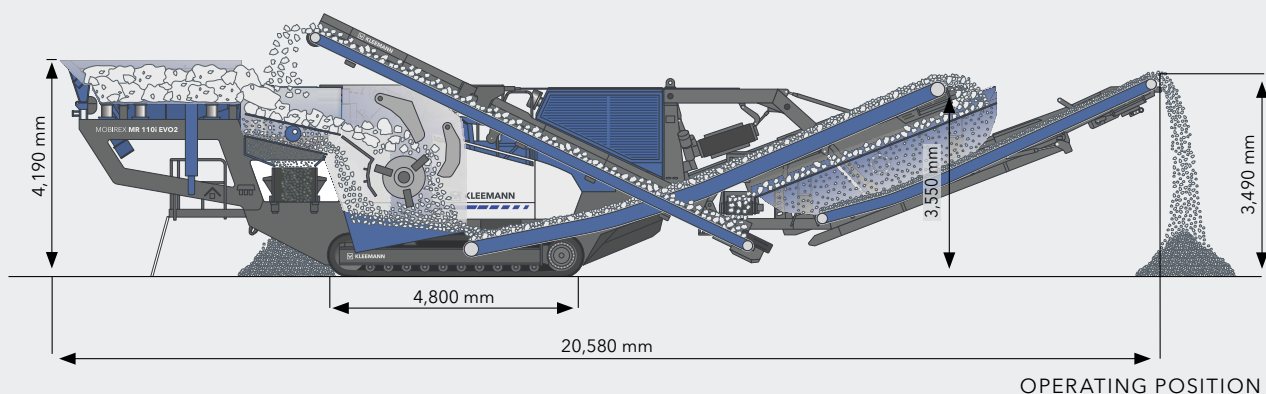



TECHNICAL HIGHLIGHTS

- Optimised material flow as a result of extending system widths
- Hydraulic gap setting
- Simple and intuitive control concept SPECTIVE
- Efficient and powerful diesel direct-drive
- High-performance secondary screening unit with oversize grain returning (option)

TECHNICAL INFORMATION MR 110(i) EVO2

Feeding unit

Feed capacity up to approx. (t/h) ¹⁾	350
Feed size max. (mm)	880 x 550
Feed height (with extension) (mm)	4,190 (4,550)
Hopper volume (with extension) (m ³)	4,4 (8)
Width x length (with extension) (mm)	2,100 x 3,700 (2,800 x 3,700)

Vibrating feeder

Width x length (mm)	900 x 2,600
---------------------	-------------

Prescreening

Type	double-deck heavy-piece screen
Width x length (mm)	1,010 x 2,100

Side discharge conveyor rigid (optional)

Width x length (extended) (mm)	650 x 4,000 (6,000)
Discharge height approx. (extended) (mm)	2,900 (3,650)

Crusher

Impact crusher type	SHB 110-080
Crusher inlet width x height (mm)	1,100 x 800
Crusher weight approx. (kg)	13,000
Rotor diameter (mm)	1,100
Crusher drive type approx. (kW)	direct, 310
Adjustment of impact toggles	infinitely variable, fully hydraulic
Crushing capacity with demolished concrete up to approx. (t/h)	240 ²⁾
Crushing capacity with rubble up to approx. (t/h)	240 ²⁾
Crushing capacity with broken asphalt up to approx. (t/h)	205 ³⁾
Crushing capacity with limestone up to approx. (t/h)	210 ²⁾

Discharge chute

Width x length (mm)	1,200 x 2,400
---------------------	---------------

Crusher discharge conveyor

Width x length (mm)	1,200 x 9,300
Discharge height approx. (mm)	3,550

Power supply unit

Drive concept	Diesel direct ⁴⁾
Drive output of Scania diesel engine (kW)	368 - 410 ⁵⁾
Generator (kVA)	135

Secondary screening unit (optional)

Type	single-deck lightweight screen
Width x length (mm)	1,350 x 4,550
Return conveyor (mm)	500 x 9,100
Discharge height of fine grain discharge conveyor approx. (mm)	3,490

Transport

Transport dimensions without options

Transport height (mm)	3,600
Transport length (mm)	17,340
Transport width	3,000

Transport dimensions with secondary screening unit

Transport length with screening unit (mm)	21,110
Transport width with screening unit (mm)	3,050

Transport weight screening unit (kg)	6,100
Transport weight of basic plant - max. configuration (kg)	44,500 - 58,000

¹⁾ dependent on the type and composition of the feed material, the feed size, the prescreening, as well as the desired final grain size

²⁾ for final grain size 0 - 45 mm with approx. 10 - 15% oversize grain

³⁾ for final grain size 0 - 32 mm with approx. 10 - 15% oversize grain

⁴⁾ all ancillary electric drives

⁵⁾ depending on the respective exhaust emission standard



MOBIREX MR 110(i) EVO2

The mobile impact crusher MOBIREX MR 110(i) EVO2 can be deployed universally and produces first class final product quality. With a crusher inlet of 1100 mm and numerous technical highlights, a formidable production rate can be achieved with best cost effectiveness. Thanks to its compact design, the machine is easy to transport and can be assembled and disassembled again quickly.

STANDARD EQUIPMENT

- ❑ Hydraulically foldable feed hopper, can be operated from the ground
- ❑ Frequency-controlled vibrating feeder
- ❑ Frequency-controlled prescreen
- ❑ Prescreen with slotted grate or punched plate (upper deck) and wire cloth mesh (lower deck)
- ❑ Impact crusher with blow bars set manganese
- ❑ Continuous Feed System CFS: for optimal and continuous crusher feed
- ❑ Automatic crusher gap adjustment
- ❑ Integrated overload protection
- ❑ Lock & Turn (rotor turning and locking device): Device for safely turning and locking the rotor for service purposes or blockages
- ❑ Swivel arm for changing blow bars
- ❑ SPECTIVE control concept: menu-guided user interface, 12-inch control panel; telematic system WITOS FleetView for efficient fleet and service management
- ❑ Lockable control cabinet, dust and vibration-protection
- ❑ LED lighting
- ❑ Eye hooks
- ❑ Water spray system for dust reduction

OPTIONS

- ❑ Hopper extension: hydraulically foldable
- ❑ Side discharge conveyor 4 m, rigid: can be mounted on left or right, discharge height 2,900 mm, must be dismantled for transport, including spray system
- ❑ Extended side discharge conveyor 6 m, rigid: can be mounted on left or right, discharge height approx. 3,650 mm, must be dismantled for transport, including spray system
- ❑ Side discharge conveyor belt cover (sheet metal) in connection with rigid side discharge conveyor
- ❑ Side discharge conveyor, hydraulically folding, can be mounted on both sides, discharge height 3,390 mm, remains on machine during transport, inc. spray system
- ❑ Quick Track for selecting machine operating mode quickly and easily, operation via radio remote control
- ❑ Climate packages: Hot or cold package
- ❑ Ergonomic power pack enclosure for insulation of noise sources
- ❑ Electromagnetic separator, permanent magnet or magnet preparation
- ❑ Secondary screening unit, in convenient container dimensions, hook-lift compatible inc. spray system
- ❑ Belt scale, available for crusher discharge conveyor and fine grain conveyor (secondary screening unit)
- ❑ Wind sifter for removing foreign material and light elements from the oversize grain by means of an 11 kW blower with air outlet below the transfer conveyor
- ❑ 110 V socket
- ❑ Track pads for crawler chassis for protection of ground
- ❑ Premium lighting



SPARE PARTS

For economical operation of the machine, it is also necessary to select the correct wear parts. Original parts from KLEEMANN are optimally designed for the requirements of the user and machine. They are characterised by a long service life, excellent quality, good availability and trouble-free assembly. With application know-how and competent advice, we can find the optimum wear part for our customers to match their individual application.

BLOW BARS

Machine type	Shape blow bar	Dimensions W x H x L [mm]	Blow bars Manganese	Blow bars Martensitic	Martensitic blow bars with ceramic	Blow bars Chrome steel	Blow bars Chrome steel with ceramics
MR 110(i) EVO2	C-shape	90 x 360 x 1080	X	X	X	X	X
MR 122 Z	X-shape	130 x 340 x 1250	X	X	X		
MR 130(i) EVO2	C-shape	100 x 370 x 1280	X	X	X	X	X
MR 150 Z	X-shape	135 x 370 x 1500	X	X	X		



C-shape

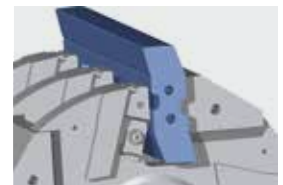

S-shape

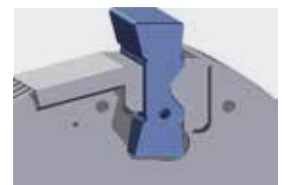

X-shape

Material	Feed material						
	Soft to medium-hard stone (e.g. limestone), river gravel < 150 N/mm	Hard stone with low abrasiveness (e.g. basalt), river gravel	Hard stone with high abrasiveness (e.g. granite), river gravel	Asphalt	Concrete low percentage ferrous material	Concrete high percentage ferrous material	Rubble
Manganese	●	●	●	●	●	●	●
Martensitic	●	● < 450 mm	●	●	●	●	●
Martensitic with ceramics	● < 450 mm	● < 450 mm	● < 450 mm	●	●	●	●
Chrome steel	● < 250 mm	● < 250 mm	● < 250 mm	●	●	●	●
Chrome steel with ceramics	● < 250 mm	● < 250 mm	● < 250 mm	●	●	●	●

● Recommended ● Partly recommended ● Not recommended
 For queries about the suitable rotor ledge, please contact your sales and service organisation.

IMPACT PLATES

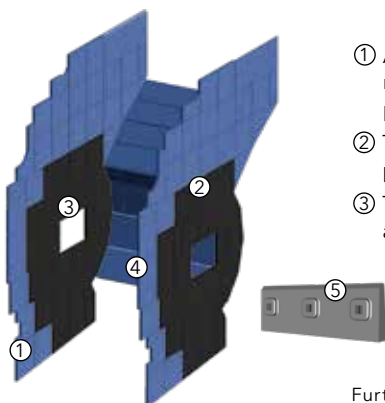

- ① All wear plates from the main wear zone with mounting hardware are included in the service package for easy exchange.
 - ② Thick-walled KLEEMANN Resistant Steel wear plates protect the housing
 - ③ The wear plates are for the most part interchangeable, greatly reducing the spare parts stock.
 - ④ The mounting hardware includes all necessary screws for a secure fit.
 - ⑤ Example for cast manganese impact plate that can be replaced individually depending on the machine and requirement.*
- * Two materials available: manganese steel and martensitic steel

Further information is available at www.partsandmore.net or in our Parts and more catalogue