



EW100

Wheeled Excavators



Quickly on the go with the EW100 mobile excavator

The 10-ton mobile excavator EW100 wins over with a power output, low fuel consumption and particularly user-friendly features. The minimized fuel consumption – with savings of up to 20 percent – is achieved through the new ECO operating mode, which allows for efficient work by reducing the rpm's and by adapting the pump: a plus for the environment and the wallet. The mobile excavator EW100 is particularly operator-friendly thanks to a drive pedal – for both road travel as well as working operation.

- 30km/h top speed
- 15% more power output with up to 20% less fuel consumption
- Equipped with a tier IVi engine
- Modern jog dial system, known in the automotive industry: the menu is intuitively operated via a rotary push button
- Maximum connection options with up to 5 auxiliary control circuits, of which 3 are individually adjustable



30 km/h offer a great mobility

The EW100 drives to the job site at up to 30 km/h – this saves time, money and the additional transport.

ECO Mode

Low-consumption work and high fuel savings.

+ 15 % power

- 20 % consumption

+ 30 % tractive force

In comparison to the previous model.





Modern jog dial system

As known in the automotive industry - the menu is handled intuitively by a jog dial system. Choose the perfect working mode:

- **ECO mode**
standard mode for efficient and fuel-saving work.
- **HI mode**
maximum pump capacity for fast and powerful work.
- **LOW mode**
For precision work.



Emission stage 3B / Tier IVi

Environmentally friendly and economic in consumption -

thanks to its exhaust emission stage 3B / Tier IVi and nearly 20% less fuel consumption. Three operating modes are available during application on the job site.



Maintenance 2.0

Connect any output device, laptop or tablet with the connection inside the cabin and instantly gain access to the maintenance diagnosis tool.

The EW100 is equipped additionally with an error code output and standard mini measurement connections.

Time is money – and downtime is expensive.



**WACKER
NEUSON**
all it takes!



Excellent service access

Access easily the service points by the tiltable cabin and the wide opening engine hood.

All maintenance components like fuel, air, oil and hydraulics filter, the water and the hydraulics cooler are easy to access.



Technical specifications

Operating data

Shipping weight min.	9,241 kg
Operating weight	9,685 - 11,036 kg
Biting force max.	47 kN
Breakout force max.	54.1 kN
Digging depth max.	4,244 mm
Dumping height	5933 - 6201 mm
Dump height max.	6,201 mm
Digging radius max.	8,107 mm
Superstructure slewing speed	10 1/min
L x W x H	6656 x 2465 x 2989 mm

Engine / Motor

Engine / Motor manufacturer	Perkins
Engine / Motor type	854E-E34TA
Engine / Motor	4-cylinder turbo diesel engine
Displacement	3,387 cm ³
RPM / speed	2,400 rpm
Engine performance according to ISO	55 kW
Battery	100 Ah
Fuel tank capacity	170 l

Hydraulic system

Duty pump	1-pump Load Sensing
Flow rate	180 l/min
Operating pressure for driving hydraulics	440 bar
Hydraulic oil tank	120 l

Undercarriage

Axles front	Oscillating steering axle
Axles rear	Rigid steering axle
Tires (standard)	Dual tires 8.25/20
Turning radius	5,570 mm
Track width	1,942 mm
Ground clearance	340 mm
Travel speed 20 km/h version, max.	20 km/h
Travel speed 30 km/h version, max.	30 km/h



**WACKER
NEUSON**
all it takes!

Dozer Blade

Width	2,454 mm
Height	500 mm
Stroke	498 mm
Stroke	132 mm

Sound level

Sound level (LwA)	96 dB(A)
-------------------	----------



**WACKER
NEUSON**
all it takes!

Dimensions

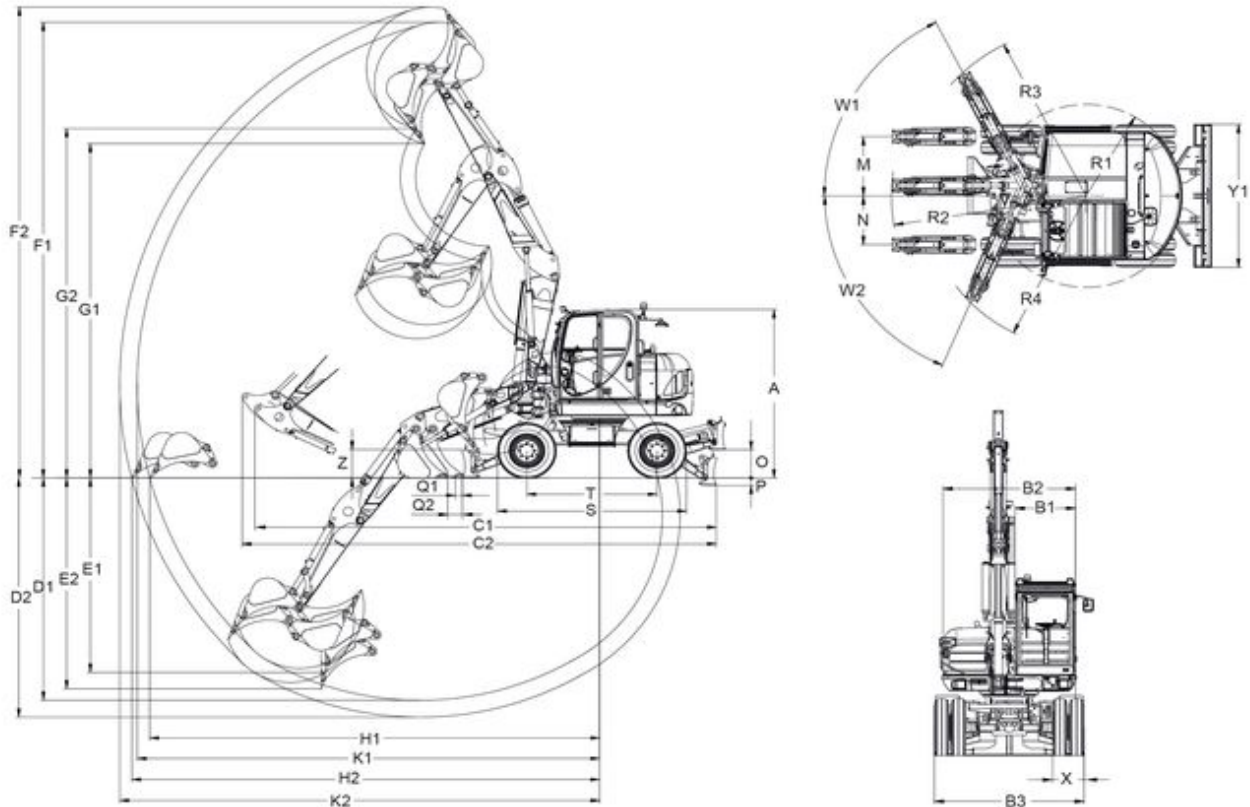

mono boom

triple boom

		mono boom	triple boom
A	Height	2,989 mm	2,989 mm
B1	Width cabin	988 mm	988 mm
B2	Width revolving superstructure	2,174 mm	2,174 mm
B3	Width traversing gear	2,454 mm	2,454 mm
C1	Transport length short ds	7,257 mm	6,656 mm
C2	Transport length long ds	7,315 mm	6,886 mm
D1	Digging depth max. max., short ds	3,998 mm	3,941 mm
D2	Digging depth max. max., long ds	4,298 mm	4,244 mm
E1	Insertion depth max., vertical, short ds	3,356 mm	3,449 mm



E2	Insertion depth max., vertical, long ds	3,648 mm	3,740 mm
F1	Insertion height max., short ds	7,294 mm	8,087 mm
F2	Insertion height max., long ds	7,483 mm	8,355 mm
G1	Dump height max. max., short ds	5,156 mm	5,933 mm
G2	Dump height max. max., long ds	5,346 mm	6,201 mm
K1	Digging radius max. max., short ds	7,541 mm	7,812 mm
K2	Digging radius max. max., long ds	7,822 mm	8,107 mm
H1	Range max. on the bottom, short ds	7,320 mm	7,602 mm
H2	Range max. on the bottom, long ds	7,611 mm	7,903 mm
O	Lift height max., dozer blade above subgrade	504 mm	504 mm
P	Scraping depth max., dozer blade below subgrade	132 mm	132 mm
S	Length total traveling gear	3,193 mm	3,193 mm
Q1	Distance bucket dozer blade (short ds)	120 mm	120 mm
Q2	Distance bucket dozer blade (long ds)	165 mm	165 mm
--	Turning angle	63 °	63 °
--	Turning angle	67 °	67 °
R2	Boom slewing radius middle	2,953 mm	3,191 mm
R3	Boom slewing radius right	2,707 mm	2,929 mm
R4	Boom slewing radius left	2,424 mm	2,639 mm
T	Length traveling gear, Turas guide wheel	2,200 mm	2,200 mm
X	Width dual tires	514 mm	514 mm
X	Width balloon tires	530 mm	530 mm
Y1	Width dozer blade	2,465 mm	2,465 mm
Z	Height Dozer blade	507 mm	507 mm

ds = dipper stick



**WACKER
NEUSON**
all it takes!

Please note

that product availability can vary from country to country. It is possible that information / products may not be available in your country. More detailed information on engine power can be found in the operator's manual; the stated power may vary due to specific operating conditions.

Subject to alterations and errors excepted. Applicable also to illustrations.

Copyright © 2018 Wacker Neuson SE.